

**Base band application
(MT6218B based platform)**

WCP/MS/SA1

Danny Wang

2004/07/07

Outline

- MT6305 overview
- MT6218B overview
- Application circuit discussion
- Connect to Driver
- Base band test items overview
- Base band related tools overview
- Communication models with customer
- END

MT6305 overview - Block diagram

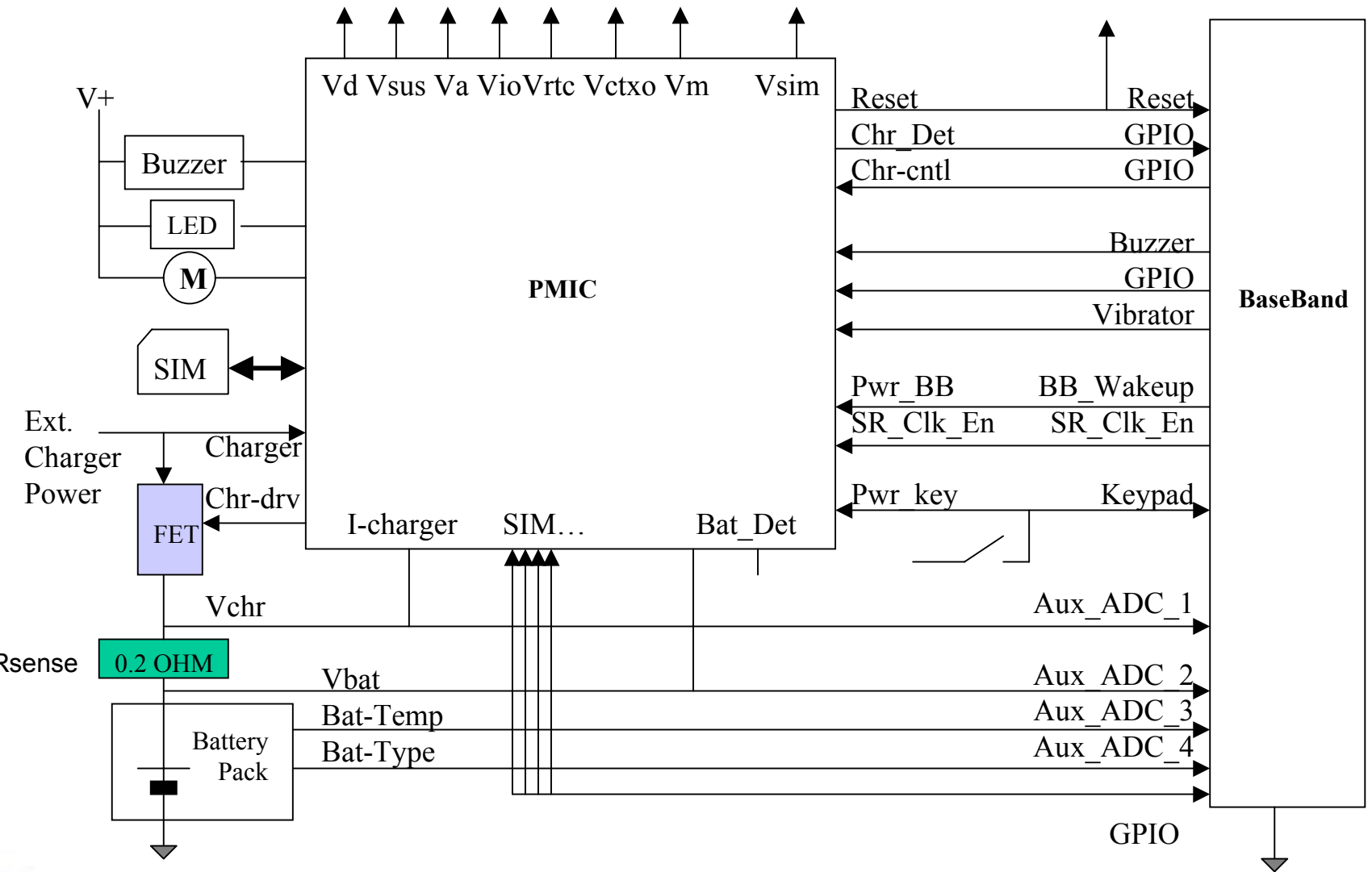

Charger state diagram

H.W.

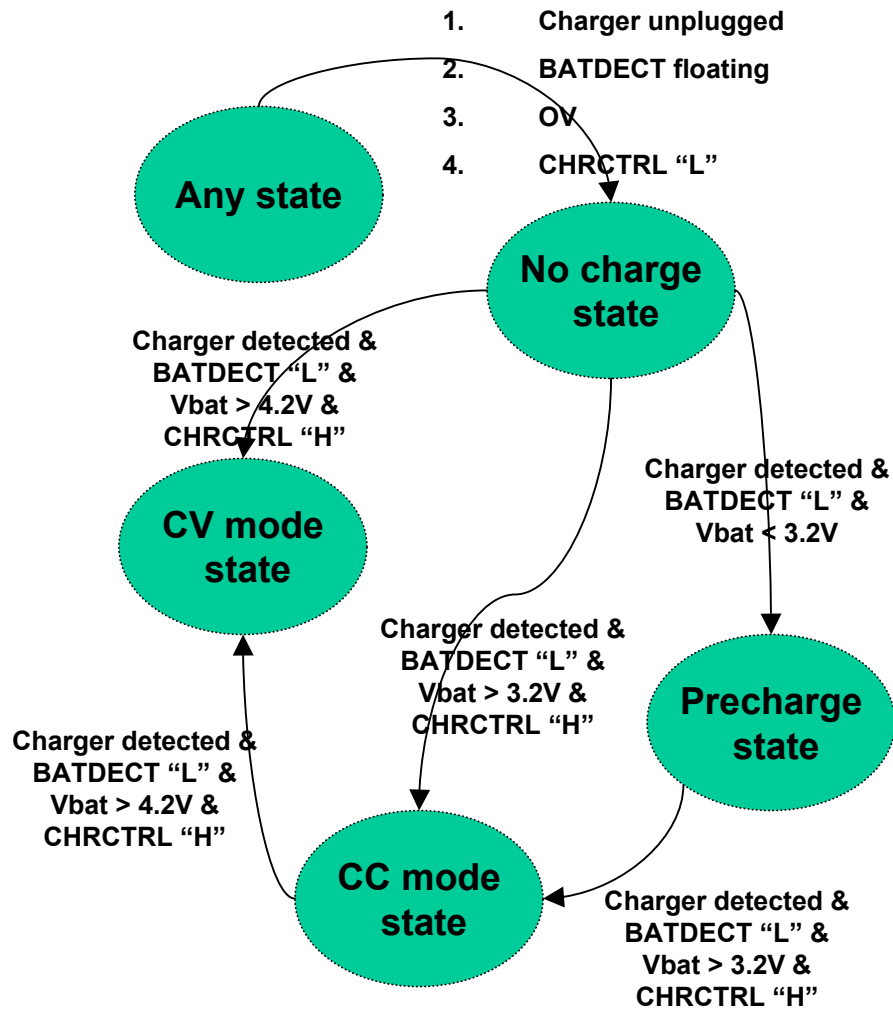

MT6305 overview - Function (1)

- Regulator
 - V_a , V_{tcxo} (2.8V, Low noise and high PSRR design, can be turned off in sleep mode by “VASEL” and “SRCLKEN”,)
 - V_m (1.8/2.8V “Vmsel”),
 - V_{core} (1.8V)
 - V_{io} (2.8V)
 - V_{sim} (3V/1.8V “SIMSEL”)
 - V_{rtc} (1.5V) (1mA)
- Reset control
 - Reset delay (2msec/nF * Crstcap)
- LDOs On/Off control
 - Charger in $> V_{bat} + 0.25V$
 - BBwake up “H”
 - OT/UVLO (3.0,3.2)
 - DDLO (2.5,2.6)

MT6305 overview - Function (2)

- Charger function
 - BATUSE (L → Li-ion, H → Ni-Mh)
 - BATDET (L → charger enabled) (5usec)
 - ✓ PMIC auto disable charging function if illegal battery is found or battery removal
 - Precharge function (Li-ion/Ni-MH)
 - ✓ Precharge current = $10\text{mV}/R_{\text{sense}}$
 - CC mode charging (Li-ion/Ni-MH)
 - ✓ CC mode charging current = $160\text{mV}/R_{\text{sense}}$
 - CV mode charging (only for Li-ion)
 - ✓ Vbat is kept to 4.2V
 - OV function (5usec)
 - ✓ 4.3 V (Li-ion), 5.1V (Ni-MH)
- Thermal shutdown (disable all regulator, exclude RTC)
- Buzzer, LED, Alerter driver (low Von voltage)
- 1.8V/3V SIM level shifter

MT6218B overview

- Application overview
- Main Features
- Interrupt controller
- Memory management
- Boot up mechanism
- External memory interface (EMI)
- Auxiliary ADC
- Pulse-Width Modulation outputs (PWM)
- Real time clock (RTC)
- Keypad
- General Purpose Inputs/Outputs (GPIOs)
- Audio block

MT6218B Overview – Typical Application

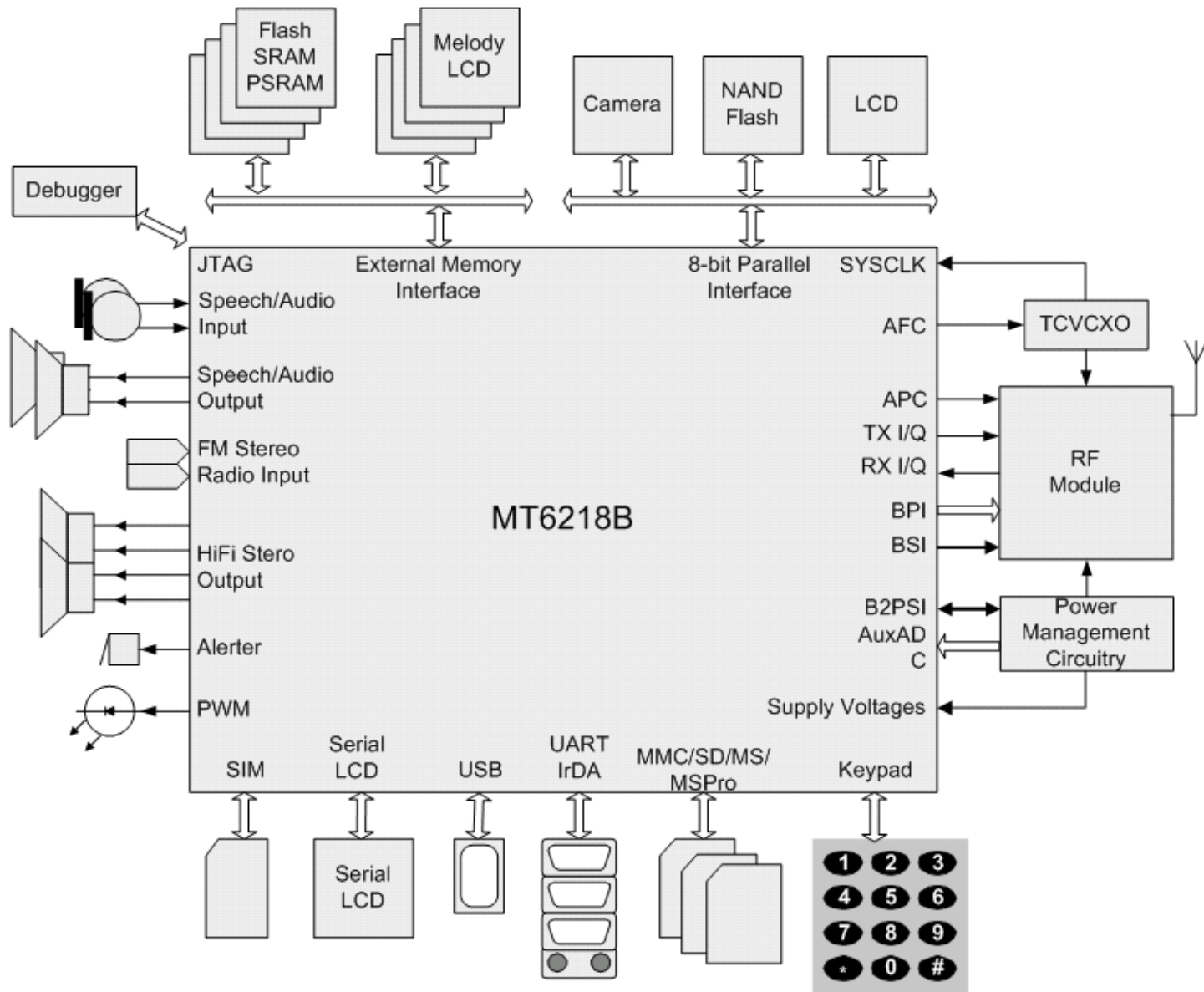

MT6218B Overview – Block Diagram

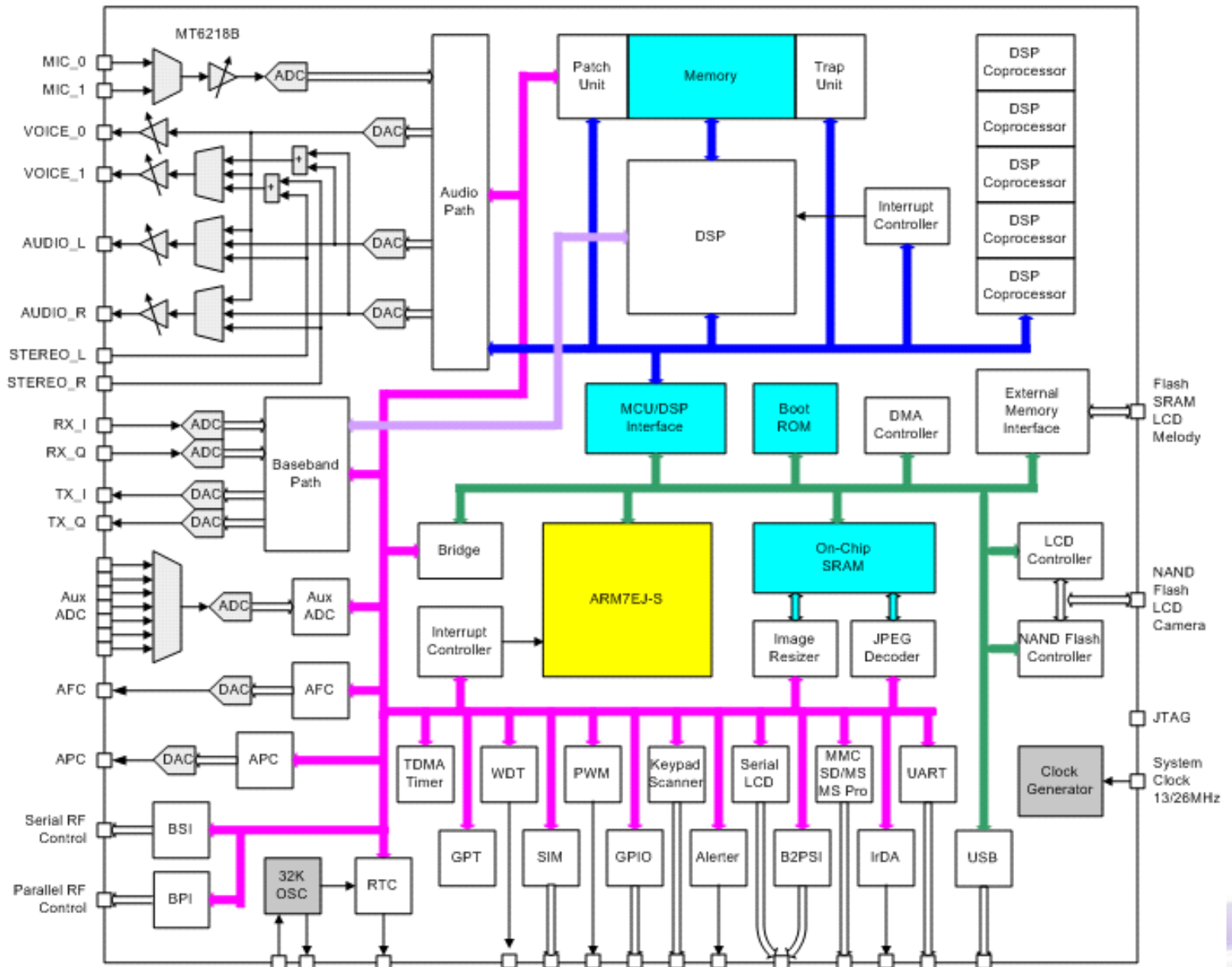

MT6218B Overview – Main Features(1/3)

- MCU system and external memory interface
 - ARM7EJ-S 32-bit RISC processor (26/52MHz)
 - Java hardware acceleration for Java-based games and other applets
 - 2M bits zero-wait-state on-chip SRAM
 - On-chip boot ROM for Factory Flash download
 - Watchdog timer for system crash recovery
- External memory interface
 - Support 8/16-bit memory components with size up to 64MB each
 - Support Flash and SRAM with page (8/16/32/64 bytes) mode or burst mode
 - Support Pseudo SRAM
 - Standard parallel LCD interface, built-in hardware acceleration function for color LCD panels
 - Flexible I/O voltage of 1.8V ~ 3V for memory interface
- Multimedia subsystem
 - Dedicated 8-bit parallel interface, support up to 3 external devices(LCM, NAND, Camera)
 - High speed hardware JPEG decoder, image resizer
 - Support LCD panel maximum resolution up to 800X600 at 16bpp
 - Interface for NAND Flash, USB 1.1 device, and MMC/SD/MS/MS pro

MT6218B Overview – Main Features(2/3)

- Audio and Modem codec
 - Wavetable synthesis with up to 64 tones
 - Two programmable acoustic compensation filters (Uplink, downlink)
 - AMR/EFR/FR/HR speech coding
 - Dial tone generation, voice memo, noise reduction, and echo suppression
 - Support GPRS class 12
- User interfaces
 - 6-row x 7-column keypad scan
 - Support three UARTs with speed up to 921600 bps
 - IrDA modulator/demodulator, Real time clock operation
 - Serial LCD interface with 7 bytes TX FIFO
 - PWM for backlight and alerter
 - Six external level sensitive interrupts with de-bounce logic (FIQ, IRQ don't)
- Audio interface
 - Two microphone inputs sharing one programmable low noise amplifier
 - Two speech outputs with dedicate programmable power amplifier
 - Half-duplex hands-free operation

MT6218B Overview – Main Features(3/3)

- Radio interface and baseband front end
 - 10 bit DAC for uplink I/Q signals, and 14 bit ADC for downlink I/Q signals
 - 10 bit DAC for APC
 - 13 bit DAC for for AFC
 - Two 3-wire control serial interface channels (BSI)
 - 10-bit parallel interface with programmable driving strength (BPI)
 - Multi-band support
- Power management
 - Power down mode for analog and digital circuits independently
 - 32KHz slow clocking at standby state
 - 7 channel 10-bit ADC for charger and battery monitoring
- Test and debug
 - Digital and analog loop back modes for both audio and base band front-end
 - DAI port complying with GSM Rec.11.10
 - JTAG port for debugging embedded MCU

MT6218B Overview – Interrupt controller

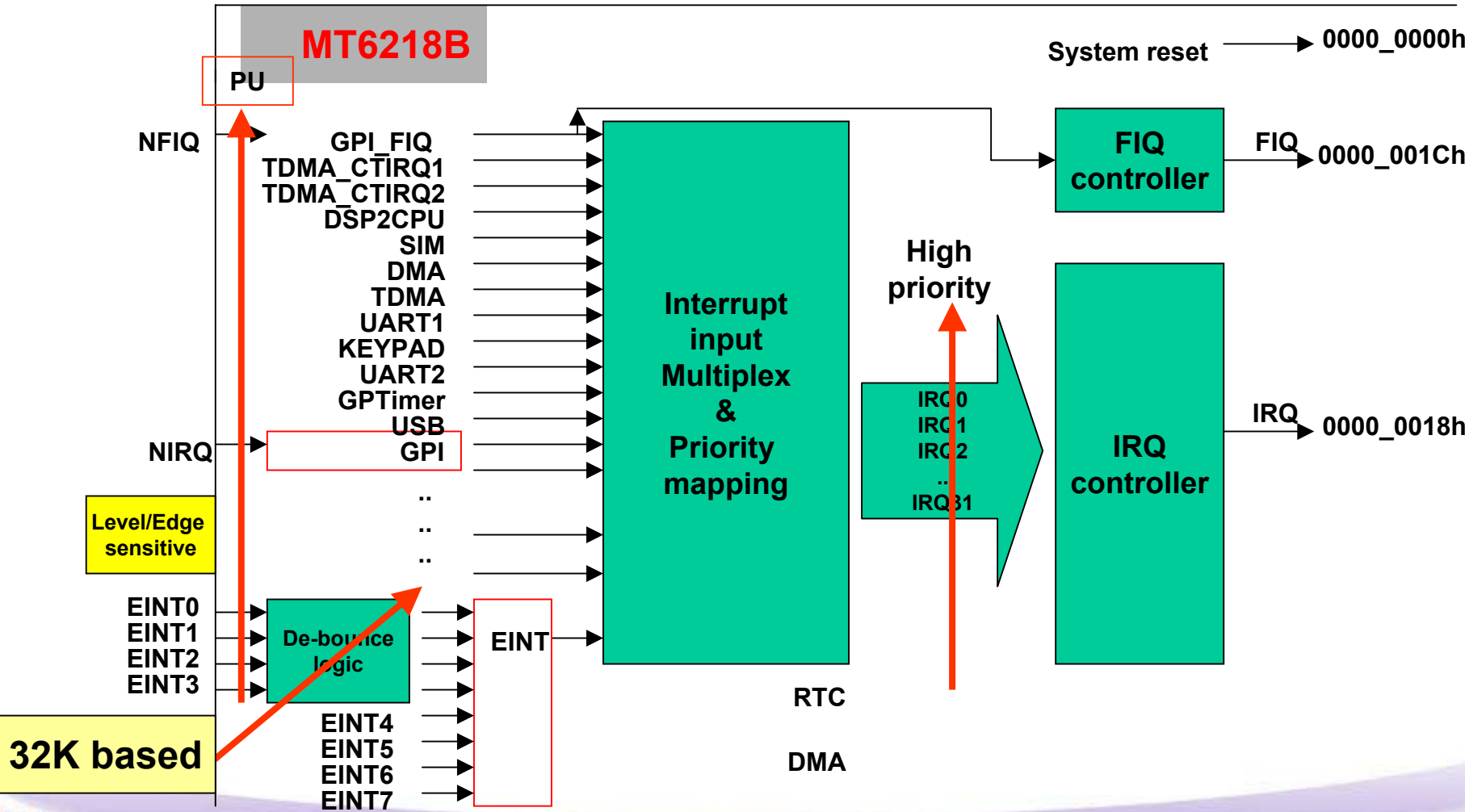

MT6218B Overview - Memory management

MCU 32-bit Addressing Space	Reserved	
MB9 9000_0000h	9800_0000h	
	9000_0000h	Virtual FIFO
MB8 8000_0000h	APB Peripherals	
MB7 7000_0000h	7800_0000h	LCD
	7000_0000h	USB
MB6 6000_0000h	MCU-DSP Interface	
MB5 5000_0000h		
MB4 4000_0000h	Internal Memory	
MB3 3000_0000h	External Memroy	
MB2 2000_0000h		
MB1 1000_0000h		
MB0 0000_0000h		

256MB {

EA[25:0]
Addressing
Space

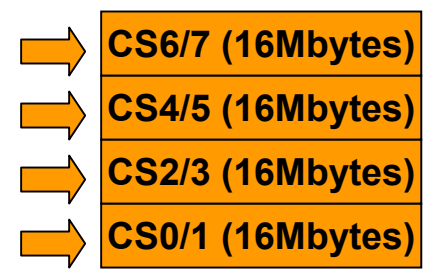

MT6218B overview - Boot up mechanism (1/2)

- EMI Re-mapping Mechanism

RM[1:0]	Address 0000_0000h (MB0)	Address 1000_0000h (MB0)
00	Boot Code	Bank1 (SRAM)
01	Bank1 (SRAM)	Bank0 (Flash)
10	Bank0 (Flash)	Bank1 (SRAM)
11	Bank1 (SRAM)	Bank0 (Flash)

- **Boot up scheme:**

- 1. Start up from Boot Code for factory programming.**
- 2. Start up from external Flash or ROM device for normal operation**

MT6218B overview - Boot up mechanism (2/2)

- SW State

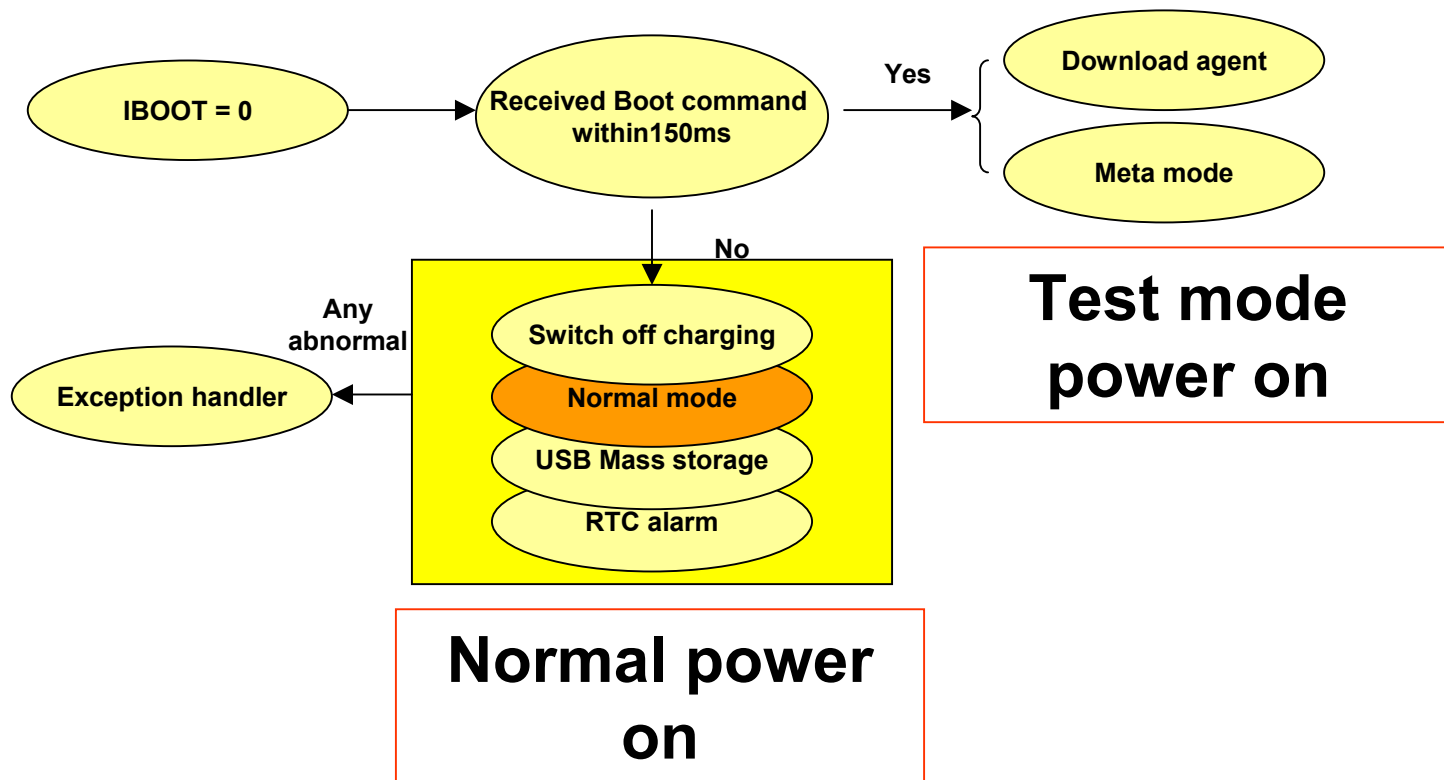

MT6218B overview - EMI

- Read cycle - C2RS, RLT setting
- Write cycle – C2WS, WST, C2WH setting

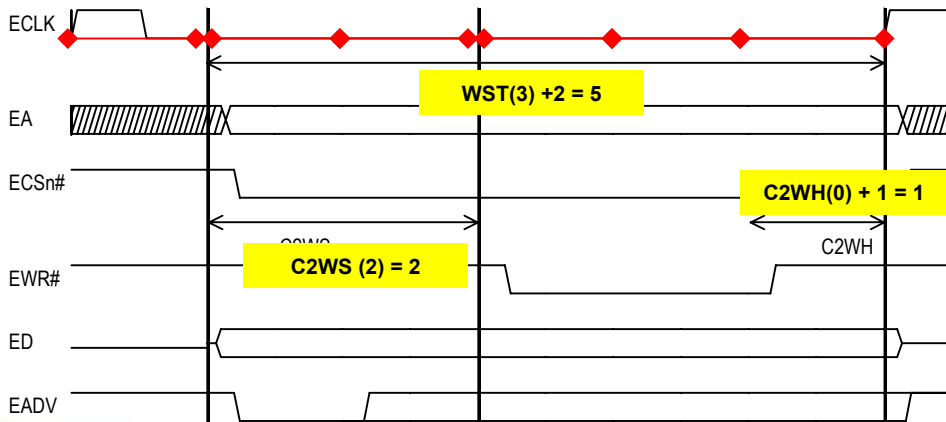
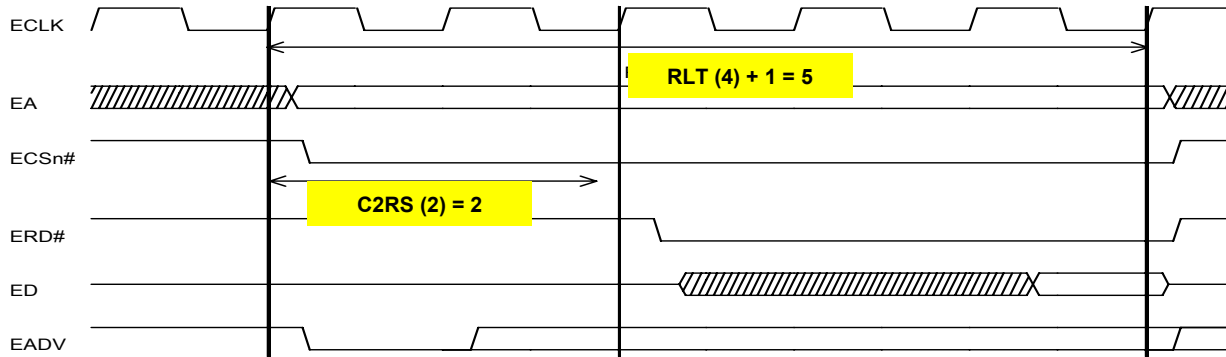

EMI



Flash (1)
Flash (2)
SRAM
NAND flash
LCM
Melody
Camera
Others ...

MT6218B overview - Auxiliary ADC

- Auxiliary ADC
 - 7 input channel
 - ✓ 10-bit resolution
 - 2 operation mode
 - ✓ immediate mode
 - ✓ timer-triggered mode (*)
 - TDMA_AUXEV0 : channel 0 only
 - » **Vbat is measured during PA turned on period**
 - TDMA_AUXEV1 : channel 0,1,2,3,4,5,6 (**VBAT, ISENSE**)
 - » **All ADC channels can be selected to measure during PA turned off period**
 - Auto or single mode
 - 8 output data register
 - ✓ DAT0,1,2,3,4,5,6 for CH0,1,2,3,4,5,6
 - ✓ DATA7 for CH0, TDMA_AUXEV0

MT6218B overview - PWM

- PWM

- PWM1/PWM2
- CLK can be 32K or 13M
- Internal CLK = CLK or CLK/2 or CLK/4 or CLK/8
- Freq. = Internal CLK/(PWM_COUNT + 1)
- Duty = PWM_THRES/(PWM_COUNT + 1)

PWM_THRES < PWM_COUNT

- Alerter

- CLK source is 13MHz only

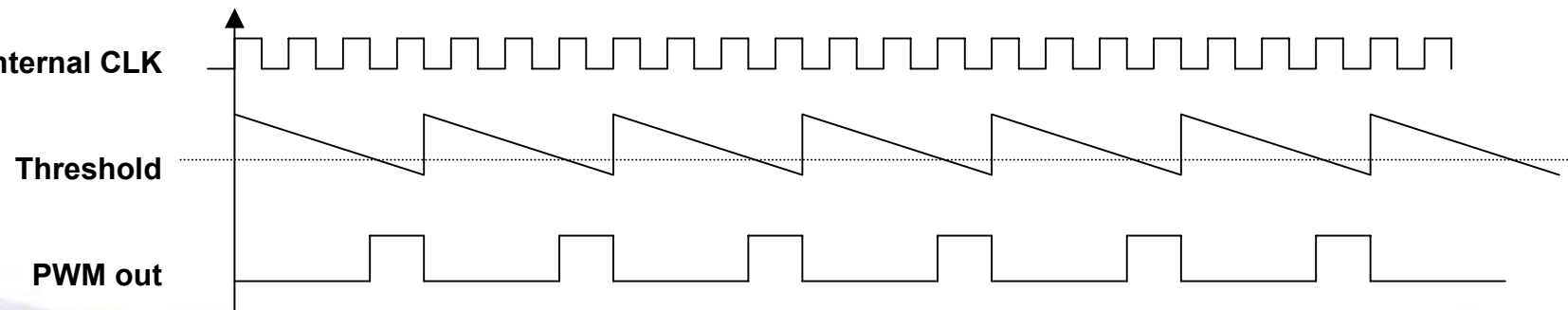

MT6218B overview - RTC

- RTC
 - Interrupt
 - ✓ Tick condition met
 - $A=(\text{SEC},\text{MIN},\text{HOU},\text{DAY},\text{WEEK},\text{MONTH},\text{YEAR}), A/2, A/4, A/8$
 - ✓ Alarm condition met
 - A
 - First power on
 - ✓ RTC_PWRKEY1 A357h, RTC_PWRKEY2 67D2h
 - ✓ 0~2048ms programmable power on debounce time
 - Baseband power up
 - ✓ BBPU : BBWKEUP
 - Write_EN (power off protection)
 - ✓ 0 : rtc write interface will be disabled until next power on.

MT6218B overview - KEYPAD

- Keypad
 - 7 columns (Input) x 6 rows (Output)
 - Detect one or two key-pressed simultaneously

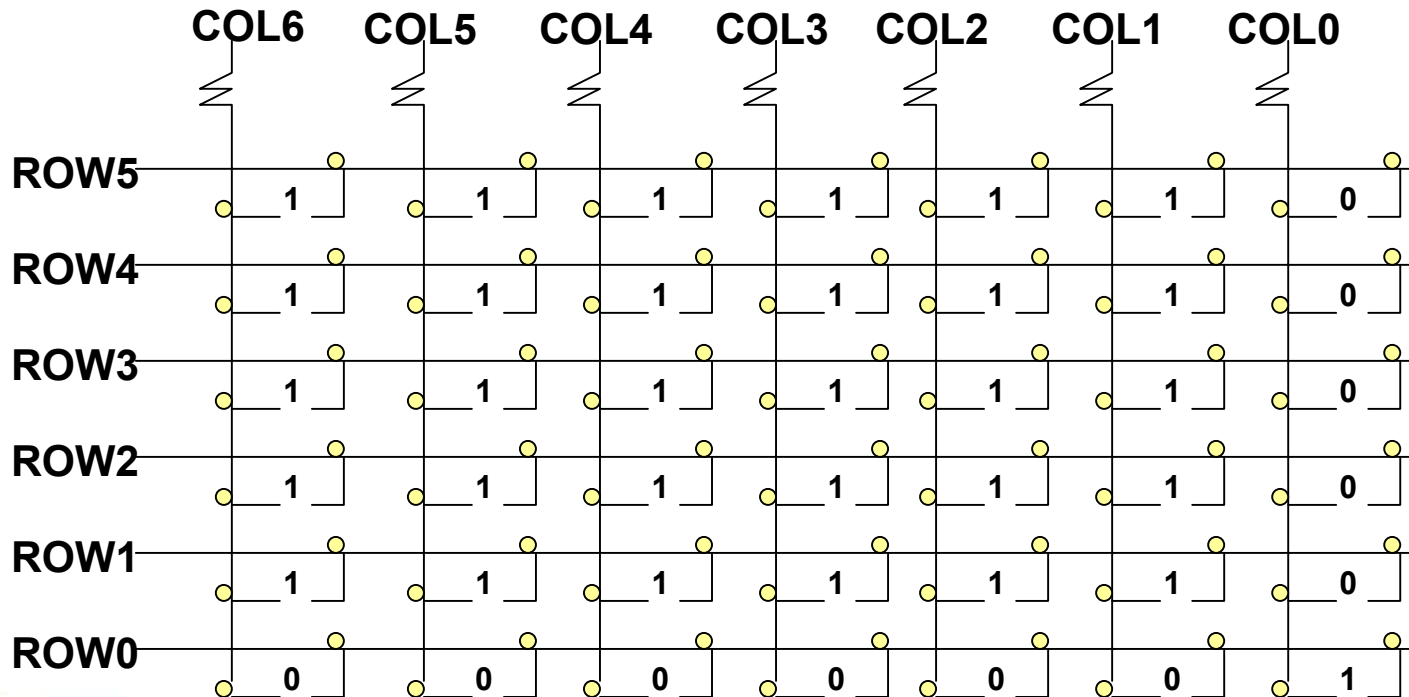

MT6218B overview - GPIOs

- GPIOs
 - Mode control (2bits)
 - ✓ GPIO,F1,F2,F3
 - ✓ Default : GPI
 - Direction
 - Pull-up/Pull down
 - Output Data

CHICAGO GPIO setting (Please set the initial value as yellow) Date : 2003/05/08 by Danny Wang

	0	1	2	3	Net Name	Description
GPIO0	DAICLK	LPT_CK	TDMA_CK	DAICLK		Reserved
GPIO1	DAIPCOUT	LPT_D2	TDMA_DI	GPIO1_LM4890OFF/DAITX		Audio amplifier enable/disable
GPIO2	DAIPCIN	LPT_D1	TDMA_D0	DAIRX		Reserved
GPIO3	DAIRST	LPT_D0	TDMA_FS	DAIRST		Reserved
GPIO4	BPI_BUS4			TXEN		RF
GPIO5	BPI_BUS5			BP15		RF
GPIO6	BPI_BUS6	BFE_PRB0		BANDSW		RF
GPIO7	BPI_BUS7	BSI_CS1		BP17		RF
GPIO8	LCD_DATA			LCDBL_EN		Enable(H)/Disable LCD backlight power supply
GPIO9	LCD_A0			GPIO9_RLED		Enable(H)/Disable Yellow LED
GPIO10	LCD_CLK			GPIO10_GLED		Enable(H)/Disable Green LED
GPIO11	/LCD_CS0			GPIO11_BLED		Enable(H)/Disable Blue LED
GPIO12	/LCD_CS1			GPIO12_CHRCTRL		Enable(H)/Disable PMIC charger block
GPIO13	13MHZ			MELODY_CLK		Melody IC clock input
GPIO14				N.C.		Reserved
GPIO15				GPIO15_VIBEN		Enable(H)/Disable Vibrator driver enable
GPIO16	PWM			BL_PWM		Keypad back light brightness control
GPIO17	/UCTS2	/UDSR1		UCTS2		Reserved
GPIO18	/URTS2	/UDTR1		URTS2		Reserved
GPIO19	URXD2			URXD2		High brightness White LED enable/disable
GPIO20	UTXD2			UTXD2		Low brightness White LED enable/disable
GPIO21	UREF_CLK	IRQ		UREF_CLK		UART reference clock input
GPO0	XLCDE	EA22		A22		Address input for 64Mbits flash
GPO1	SRCLKENAN	PWM2		LCM_BL_PWM		LCD module backlight brightness control
GPO2	SRCLKENA			VXCO_EN		Enable(H)/Disable Vtco regulator
GPO	ALERTER			LED_PWM		3 color (YGB) LED brightness control
Interrupt setting						
EINT0				EINT0_EARPHONE		Headset plug in/out detection
EINT1				EINT1_CHRDET		Charger plug in/out detection
EINT2	FIQ			EINT2_MELODY		Melody IC data request
ADC setting						
AUXADIN0				ADC0_I-		Sense charge current
AUXADIN1				ADC1_TBAT		Sense battery temperature
AUXADIN2				ADC2_MIC		Sense microphone send/off/key
AUXADIN3				ADC3_I+		Sense charge current
AUXADIN4				ADC_VCHG		Sense illegal charger plugged in
Audio setting						
AU_OUT0_P	normal mode			SPKP0		
AU_OUT0_N	normal mode			SPKN0		
AU_OUT1_P	headset mode/louder spekaer mode/ melody mode			SPKP1		
AU_OUT1_N				N.C.		
AU_VIN0_P	normal mode			MICP0		
AU_VIN0_N	normal mode			MICN0		
AU_VIN1_P	headset mode			MICP1		
AU_VIN1_N				N.C.		

MT6218B overview – Audio block (1/4)

- DSP - Speech

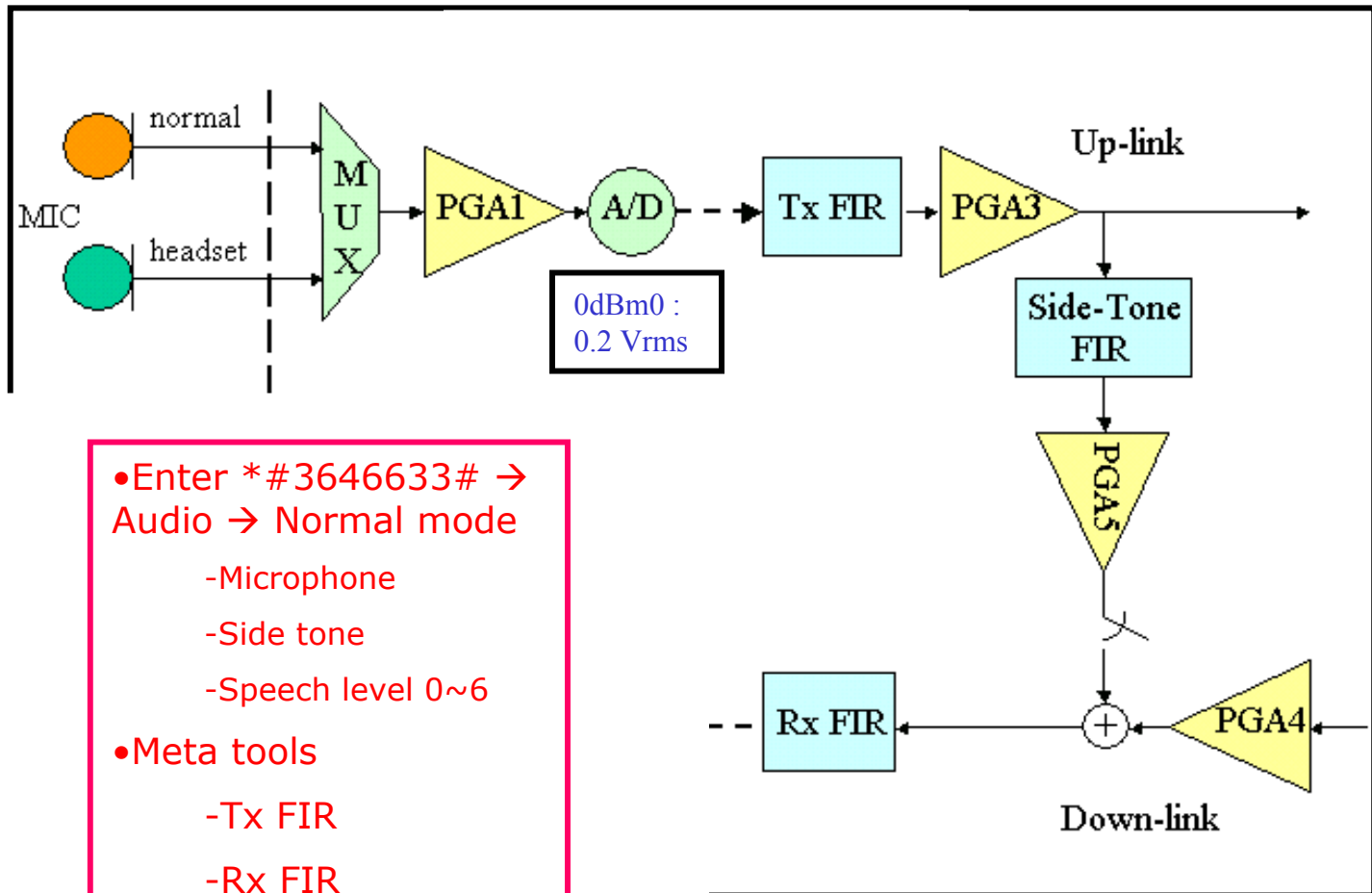

• Enter *#3646633# →
Audio → Normal mode

- Microphone
- Side tone
- Speech level 0~6

• Meta tools

- Tx FIR
- Rx FIR

MT6218B overview – Audio block (2/4)

DSP – Echo suppressor

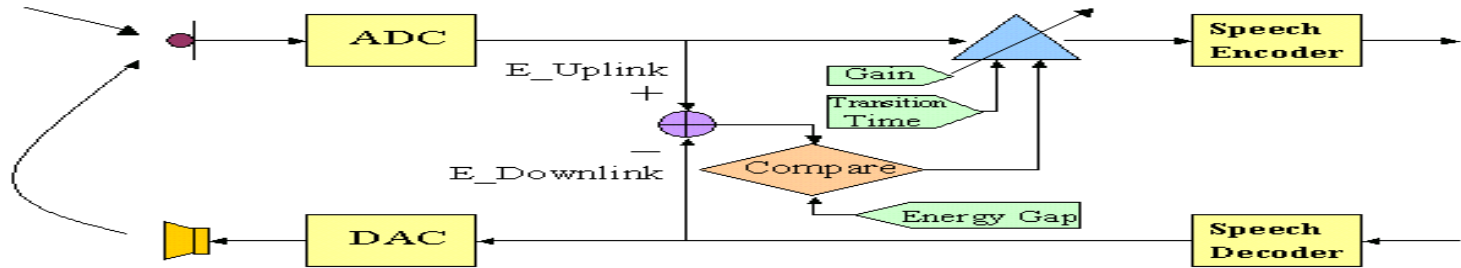

- Enter Engineer mode `*#3646633#` → Audio → Echo suppression
 - Energy Thresh 1, Delay 1 : Louder speaker mode
 - Energy Thresh 2, Delay 2 : Normal mode (max. volume only)
- Parameter descriptions
 - Energy Gap = Low byte (Energy Thresh X) * 6dB
 - Transition Time = High byte (Energy Thresh X) * 20msec
 - $1/\text{Gain} = \text{Delay X} / 32767$

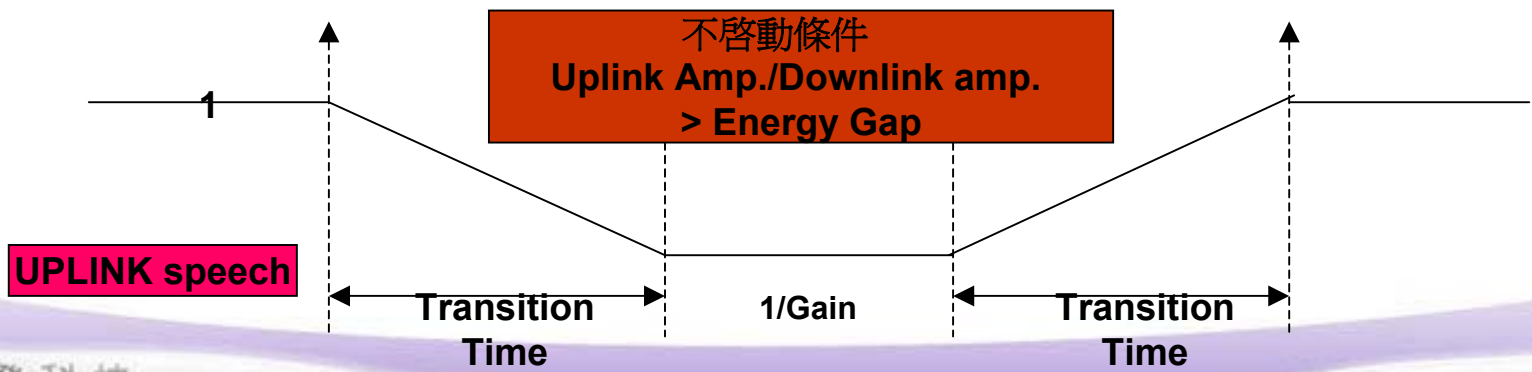

MT6218B overview – Audio block (3/4)

- DSP – Recorder
 - Idle mode
 - ✓ *.wav : PCM/ADPCM
 - ✓ *.vm : EFR (MT6205 only)
 - ✓ *.amr : AMR 5.15Kbps (MT6218, MT6219)
 - ✓ *.awb : Wide band AMR (MT6219 only)
 - Talking mode
 - ✓ *.wav : PCM/ADPCM
 - ✓ *.vm : Depend on codec type (MT6205 only)
 - ✓ *.amr : AMR 5.15Kbps (MT6218, MT6219)
 - ✓ *.awb : Wide band AMR (MT6219 only)

MT6218B overview – Audio block (4/4)

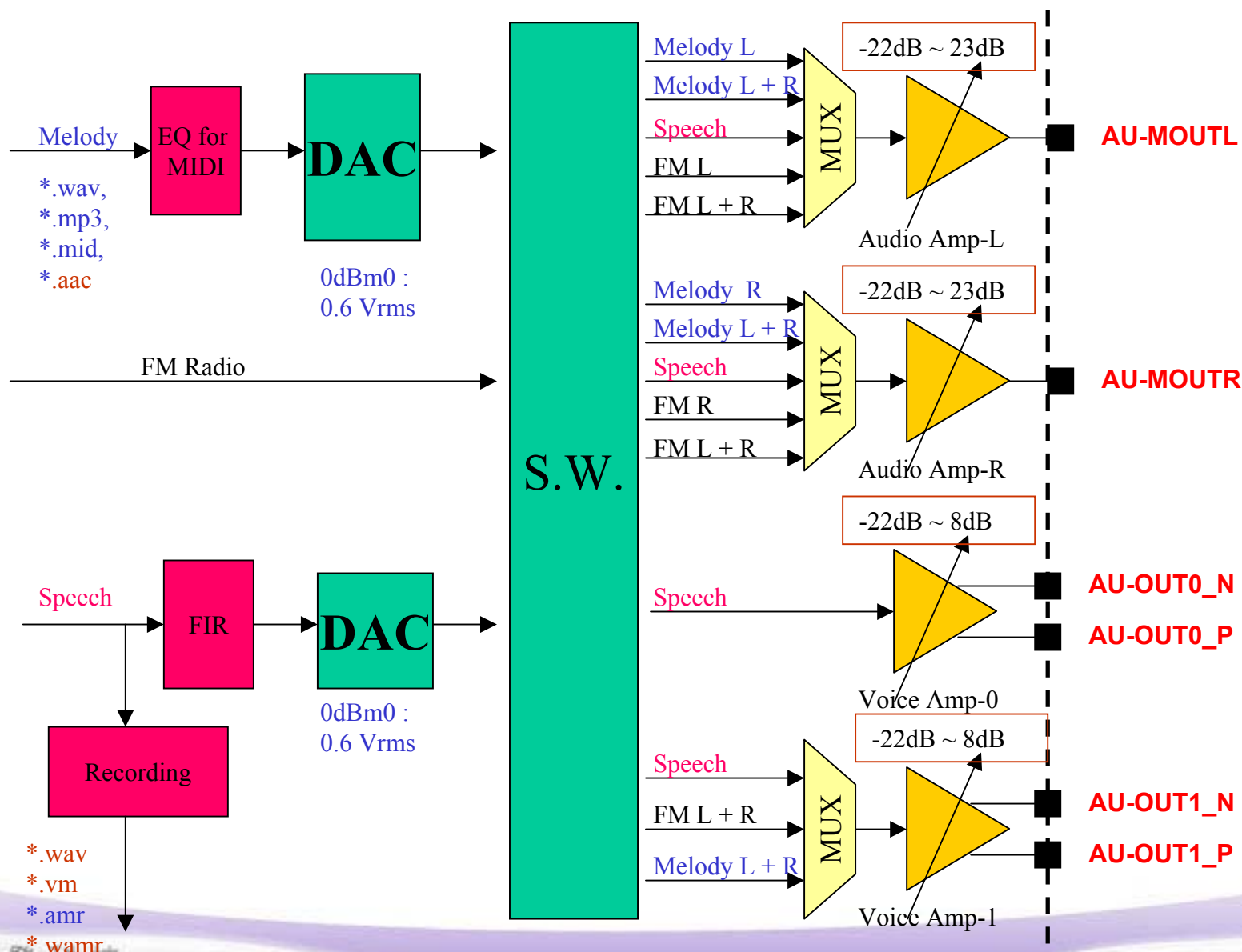

Uplink/Downlink PGA gain setting

	Uplink PGA gain	Downlink PGA gain	
		Audio Amp L/R	Voice Amp 0/1
Step size	2dB	3dB	2dB
Tunable Range	0~42dB	-22~23dB	-22~8dB
0dBm0	0.2Vrms	0.6Vrms	0.6Vrms

Enter ***#3646633#** → Audio → Normal mode/ Headset mode/LoudSp mode

Engineer mode	Microphone	Melody	Speech
Tunable Range	0~255	0~255	0~255
Step size	16 (2dB)	16 (3dB)	16 (2dB)

Application circuit discussion

- EMI & NFI & Memory Card
 - Camera
 - LCM
 - NOR Flash
 - NAND Flash
 - SRAM
 - MMC/SD/MS/MSPPro
- Power & Charger function
- Accessory Detection
- Audio
- USB
- Keypad
- SIM
- PWM
- Alerter
- Test point

MT6218 B+ Camera Module (Configuration 1)

- Camera Module attached to LCD interface

- Suitable for Clam Shell phone with Camera mounted on upper cover

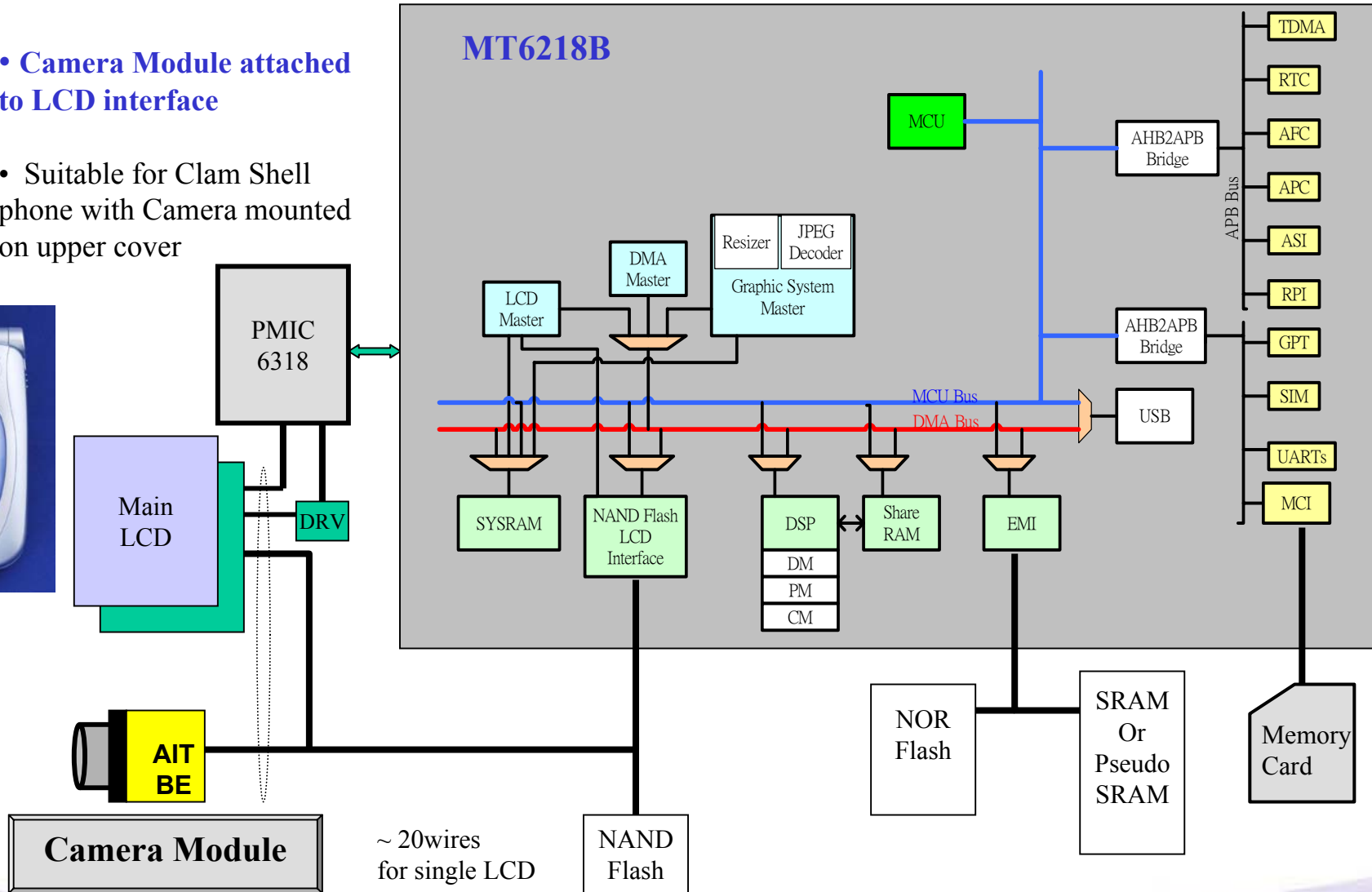

MT6218B + Camera Module configuration 2

Use Camera Modules
Prevailing in the market

- **Sensor:** Omnivision, Pixart, Hynix, etc.
- **Backend IC:** EPSON, Rohm, Corelogic, AIT P800, etc.

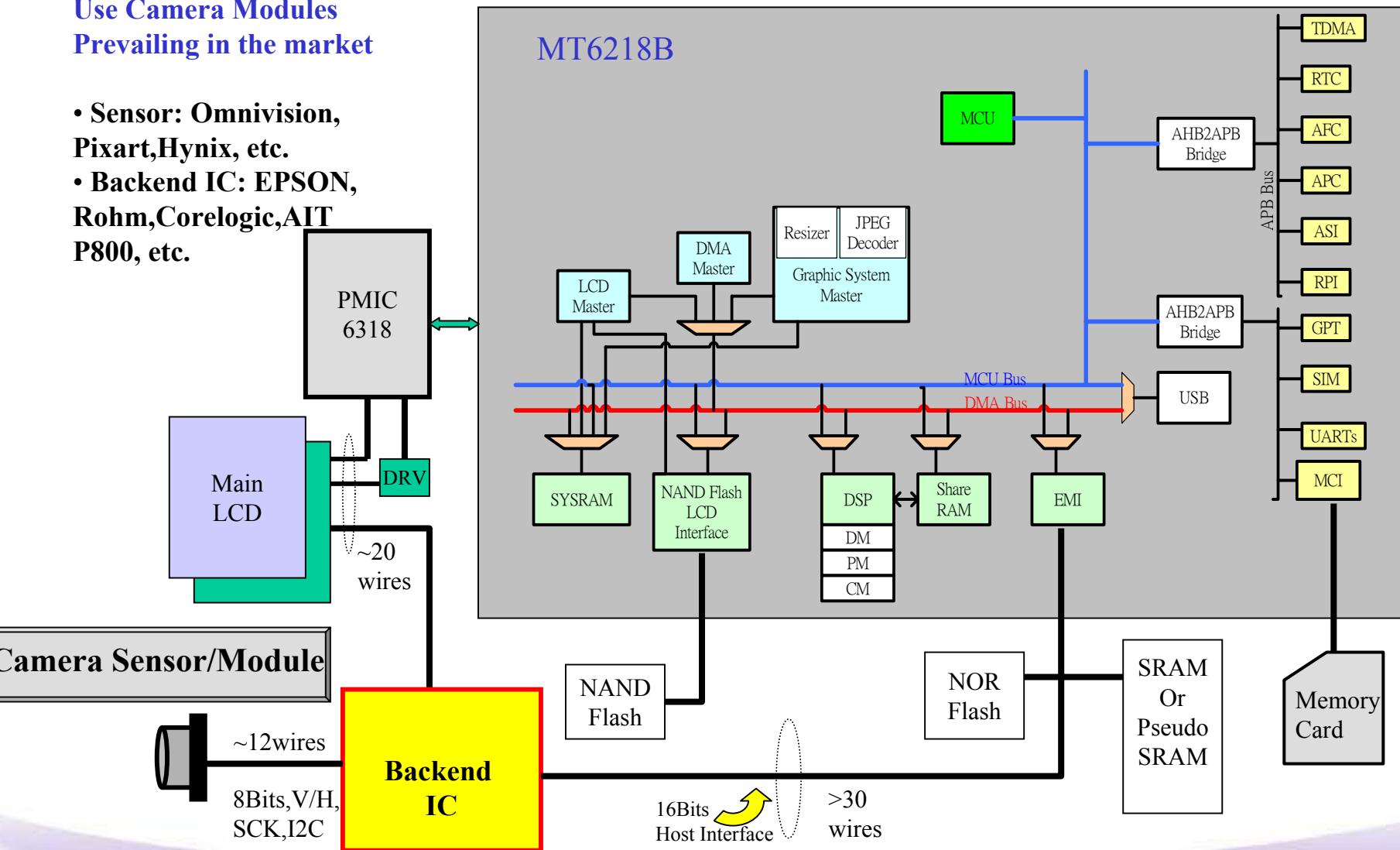

Application circuit - Power & Charger function

- Charger selection
 - Max. charger voltage 15V
 - Max. battery charge current (1C for Li-ion 600mAHr)
 - Max. power dissipation of external PMOS (1W)
 - ✓ $(V_{chg}-3.2-0.6)*0.6 < 1 \rightarrow V_{chg} < 5.73V$
 - ✓ $(V_{chg}-3.2-0.6)*0.4 < 1 \rightarrow V_{chg} < 6.3V$
 - ✓ $(V_{chg}-3.2-0.6)*0.2 < 1 \rightarrow V_{chg} < 8.8V$
 - ✓ $(15-3.2-0.6) * I < 1 \rightarrow I < 99mA$
 - Fast charge (CC mode charging current always = 1C)
 - ✓ $(V_{chg} - V_{Bat}-V_{diode} - V_{on} > 0 \rightarrow V_{chg} > 4.2 + 0.6 + 0.2 = 5V$
 - Any charging time $V_{CHG} > V_{BAT} + 0.3 \rightarrow V_{CHG} > 4.5 V$

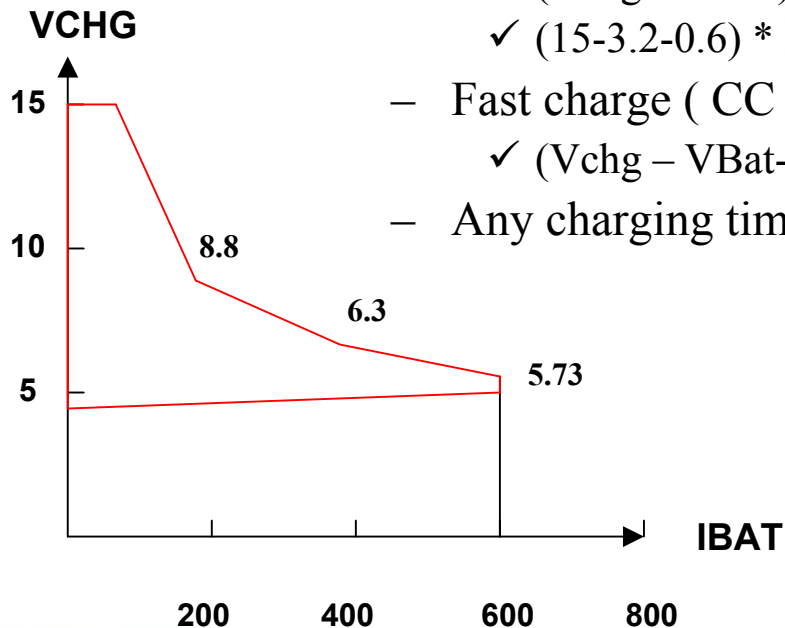

Application circuit - Power & Charger function

- AUXADC circuit
 - Rsense, BATEMP curve, ENVTMP curve

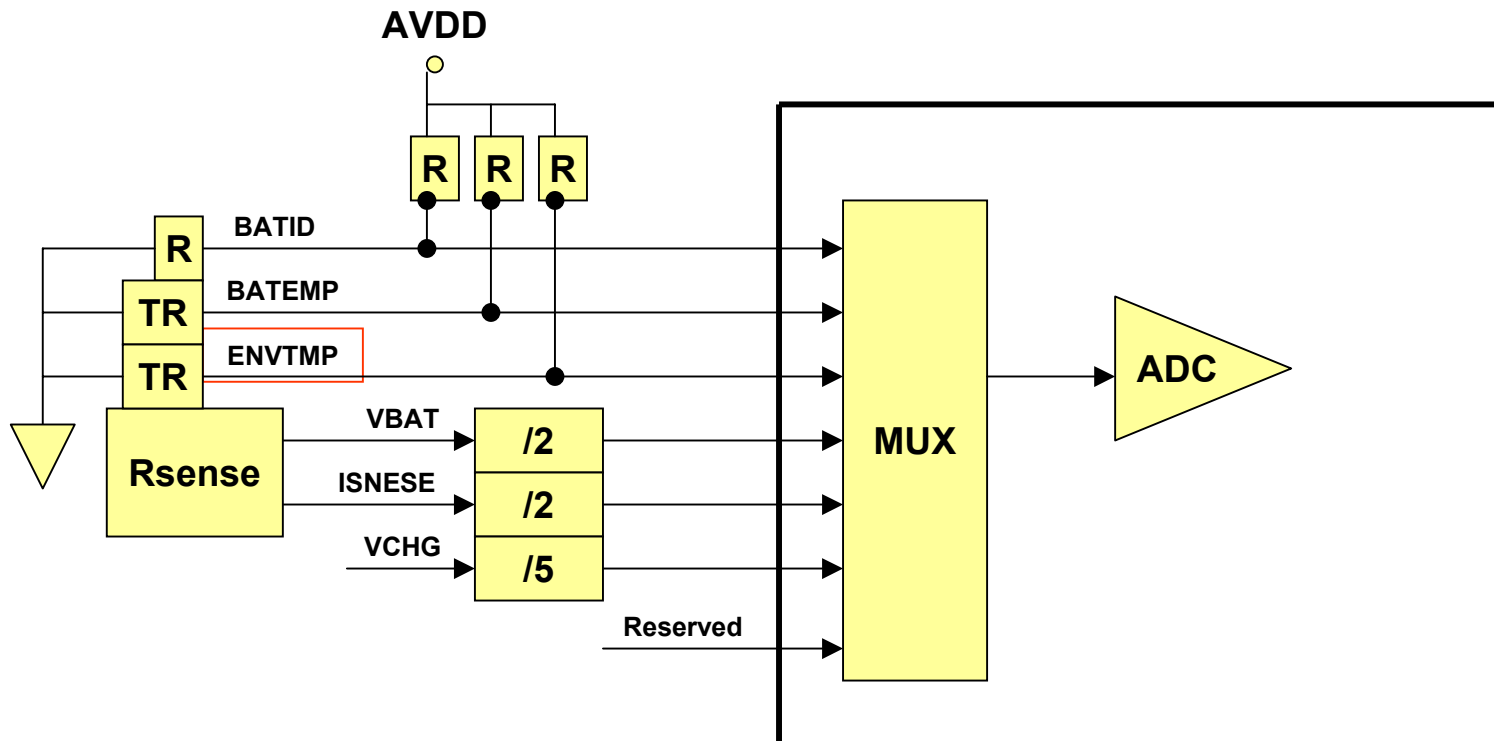

Application circuit - Power & Charger function

- Enter `*#3646633#` → device → Set default level → battery
 - LEV1 : Power off
 - LEV2 : Transmit disable
 - LEV3 : Low battery alarm
 - LEV4 : Battery level 0 → 1
 - LEV5 : Battery level 1 → 2
 - LEV6 : Battery level 2 → 3

Application circuit - Power & Charger function

1. Check ADC fail,
2. Safety timer timeout (6hr)
3. Charger plugged out

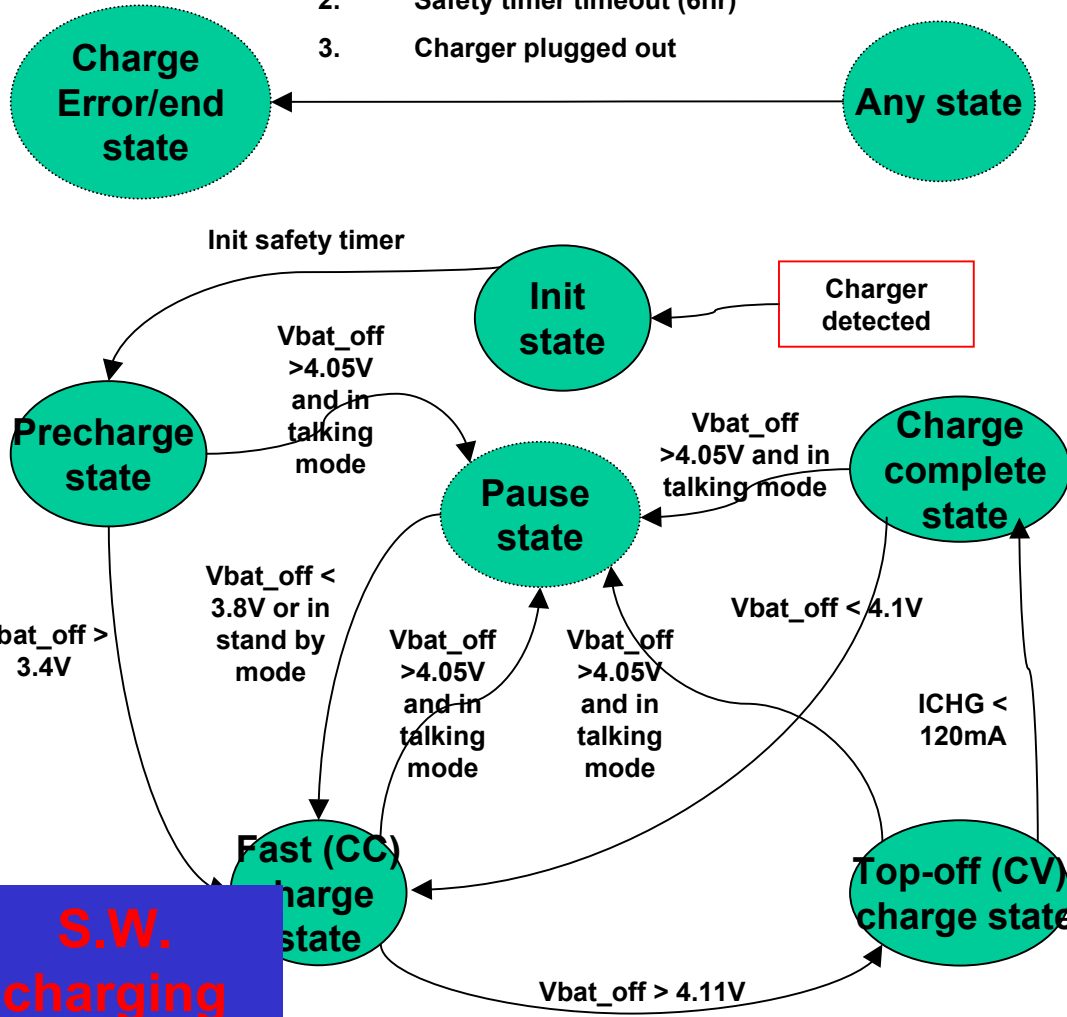

S.W. charging algorithm

ADC check for abnormal condition

- a. $V_{bat} > 4.5V \rightarrow$ **Battery over voltage**
- b. $V_{chg} > 6.5$ or $V_{chg} < 3 \rightarrow$ **Invalid charger**
- c. $BATEMP < 0oC$ or $BATEMP > 45oC \rightarrow$ **Battery temp. too cold or over heat**
- d. $BATID \rightarrow$ **N.A.**
- e. $ICHG_{on} > 1A$ or $ICHG_{on} < 20mA \rightarrow$ **Invalid charger or battery**
- f. $ICHG_{off} > 1A \rightarrow$ **Charger fail**

P.S. **XXX_on** : ADC value is measured during pulse on charging and RF off state.

xxx_off : ADC value is measured during pulse off charging and RF off state.

xxx : ADC value is measured during pulse on and pulse off charging and RF off state.

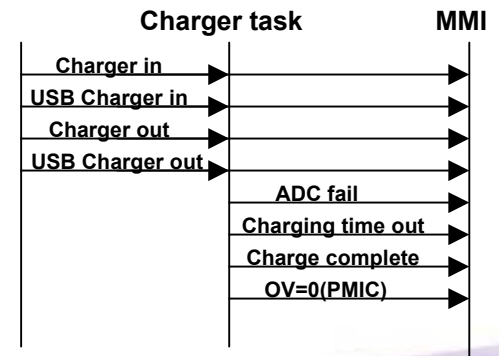

Application circuit - Power & Charger function

- S.W. protection mechanism for charging
 - $0 < \text{BATEMP} < 50$ degree C (from battery spec.)
 - $4.5 < \text{VCHG} < 6.5$ V (from PMIC spec. and charger spec.)
 - $\text{ICHG} < 800\text{mA}$ (from charger & battery spec.)
 - BATID (N.A.)
 - OV ($\text{VBAT} > 4.5\text{V}$) (from battery spec.)
 - Safety timer 6Hr

ADC calibration and measurement

- 2 channel ADC calibration is a must.
 - Worse case 下如不做 calibration, charging current 在 4.2V 會有 $4.2 * (101/200 - 99/200) * 2 / 0.33 = 250\text{mA}$ 的誤差, 會使得電池永遠都充不飽
 - ADC calibration. summary 如下.
 - ✓ a. calibration VBAT 3.4/4.2 兩點在 ADC channel 0 and channel 3
 - ✓ b. ADC channel 1,2,4 的 slope/offset 直接 copy ADC0
- 請特別注意只要 ADC(10bits) calibration 有正負 1 個 bit 的誤差 即會產生 $2.8/1024 * 2/0.33 * 2 = 34\text{mA}$
- 建議 ADC pass criterion 為
 - 1. ADC0 : test at 3.6V $\pm 40\text{mV}$ (等 factory 有大量資料後再做修正)
 - 2. ADC3-ADC0/0.33 > 20mA (等 factory 有大量資料後再做修正)

Application circuit - RTC function

- For S.W. power on latch (power on key detection)
 - $V_{RTC} > 0.8V$ is a must ($0.8V$ is a minimal working voltage of RTC block)
 - 2 sec debounce time (first power on)
- RTC charging current $< 1\sim 5mA$ (from PMIC spec.)
 - If charge current $> 1mA$, V_{rtc} will have a big drop. In order to complete a normal power on @ RTC cap deep discharge. RTC charging current $< 1mA$ is a must
- RTC charge current must be limited to $1.5V/4K = 0.375mA$
 - $V_{rtc}cap$ maximal rising time = $40mF * 0.8 / 0.375 mA = 85 sec$
 - $V_{rtc}cap$ full charging time = 160 sec. Stand by time $> 10Hr$

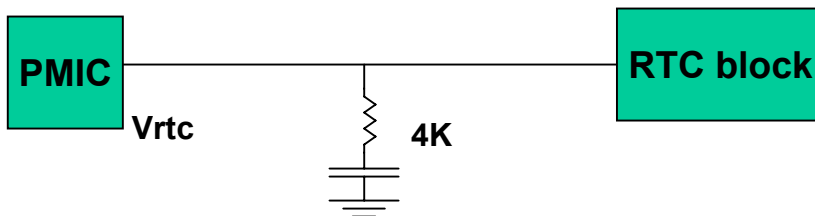

Application circuit - Accessory detection

- Bottom connector (Download cable/Earphone)
 - One interrupt pin is used to detect accessory plugged in/out.
 - One ADC channel is used to detect accessory ID.
- Earphone Jack
 - One interrupt pin is used to detect accessory plugged in/out.
 - One ADC channel is used to detect accessory ID.
- USB & Charger
 - 2 Interrupt
 - 1 interrupt + 1 ADC

Application circuit discussion - Audio

- External audio device configuration

Case	Earphone	Louder speaker
1	Mono	Mono
2	Mono	Stereo
3	Stereo	Mono
4	Stereo	Stereo

Case 3 Stereo Mono

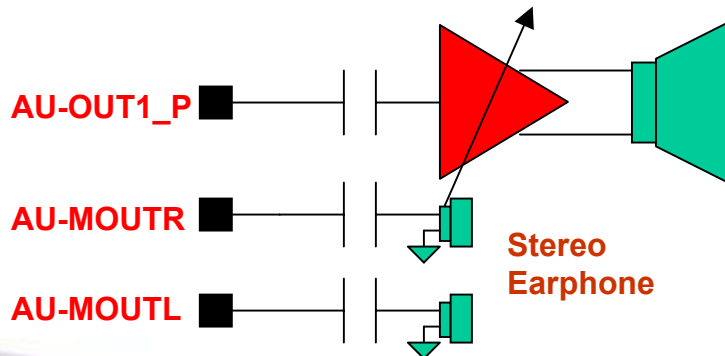

Case 4 Stereo Stereo

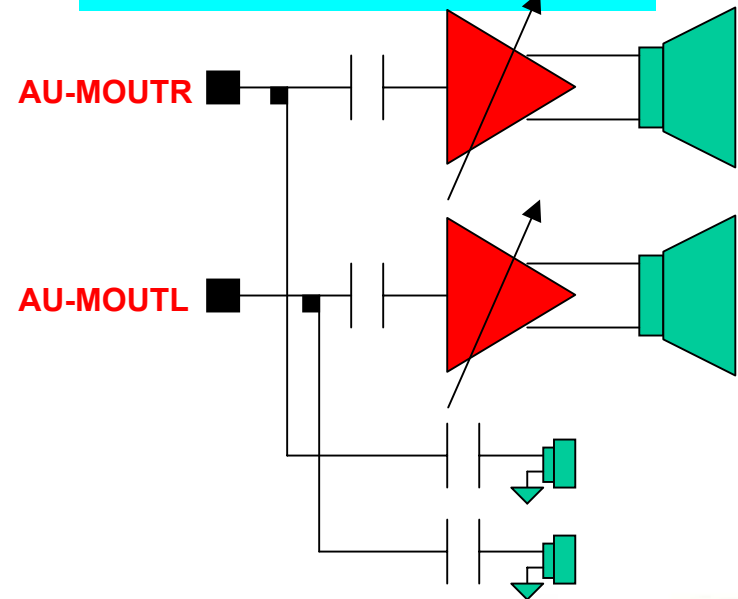

Application circuit discussion - Audio

- Audio Gain budget planning
 - Earphone : External 430 ohm is suggested

Digital output			Analog PGA			External resistor 430 ohm	Vpp of earphone	Power dissipation of earphone
dBm0	Vrms(V)	Vpp(V)	PGA Gain	Vpp(V)	Setting	Gain (dB)	Vpp(V) 430	Vpp(V) 430
-3	0.424767471	1.201423836	-22	0.095432487	0	-23.1898399	0.006610042	0.000170674
-3	0.424767471	1.201423836	-19	0.134801972	16	-23.1898399	0.009336933	0.00034054
-3	0.424767471	1.201423836	-16	0.190412846	32	-23.1898399	0.013188769	0.000679467
-3	0.424767471	1.201423836	-13	0.268965294	48	-23.1898399	0.018629631	0.001355715
-3	0.424767471	1.201423836	-10	0.379923576	64	-23.1898399	0.026315053	0.002705008
-3	0.424767471	1.201423836	-7	0.536656315	80	-23.1898399	0.037171	0.0053972
-3	0.424767471	1.201423836	-4	0.758047193	96	-23.1898399	0.052505433	0.01076883
-3	0.424767471	1.201423836	-1	1.070770121	112	-23.1898399	0.074165896	0.021486641
-3	0.424767471	1.201423836	2	1.512502997	128	-23.1898399	0.104762112	0.042871485
-3	0.424767471	1.201423836	5	2.13646727	144	-23.1898399	0.147980417	0.085539859
-3	0.424767471	1.201423836	8	3.017842231	160	-23.1898399	0.209027895	0.170674456
-3	0.424767471	1.201423836	11	4.2628263	176	-23.1898399	0.29749	0.340540311
-3	0.424767471	1.201423836	14	6.02138886	192	-23.1898399	0.41481	0.679467249
-3	0.424767471	1.201423836	17	8.50542397	208	-23.1898399	0.57651	1.355715396
-3	0.424767471	1.201423836	20	12.0142836	224	-23.1898399	0.83215038	2.705007839
-3	0.424767471	1.201423836	23	16.970275	240	-23.1898399	1.175450234	5.397200202

Single-end 2.8V
Differential 5.6V

Reserved for speech



Application circuit discussion - Audio

- Audio Gain budget planning
 - Louder speaker (External amp. Gain = 8 is suggested)

Digital output			Analog PGA			External Loud Speaker Amp.							
dBm0	Vrms(V)	Vpp(V)	PGA Gain	Vpp(V)	Setting	Gain (dB)	Gain (dB)	Gain (dB)	Gain (dB)	Vpp(V) 24	Vpp(V) 18	Vpp(V) 12	Vpp(V) 6
-3	0.42476747	1.2014238	-22	0.095432487	0	24	18	12	6	1.512502997	0.758047193	0.379923576	0.190412846
-3	0.42476747	1.2014238	-20	0.120142384	16	24	18	12	6	1.904128458	0.954324875	0.478295444	0.23971557
-3	0.42476747	1.2014238	-18	0.1512503	32	24	18	12	6	2.397155704	1.201423836	0.602138289	0.301784023
-3	0.42476747	1.2014238	-16	0.190412846	48	24	18	12	6	3.017840231	1.512502997	0.758047193	0.379923576
-3	0.42476747	1.2014238	-14	0.23971557	64	24	18	12	6	3.799235756	1.904128458	0.954324875	0.478295444
-3	0.42476747	1.2014238	-12	0.301784023	80	24	18	12	6	4.782954438	2.397155704	1.201423836	0.602138289
-3	0.42476747	1.2014238	-10	0.379923576	96	24	18	12	6	6.021382886	3.017840231	1.512502997	0.758047193
-3	0.42476747	1.2014238	-8	0.478295444	112	24	18	12	6	7.580471929	3.799235756	1.904128458	0.954324875
-3	0.42476747	1.2014238	-6	0.602138289	128	24	18	12	6	9.543248745	4.782954438	2.397155704	1.201423836
-3	0.42476747	1.2014238	-4	0.758047193	144	24	18	12	6	12.01423836	6.021382886	3.017840231	1.512502997
-3	0.42476747	1.2014238	-2	0.954324875	160	24	18	12	6	15.12502997	7.580471929	3.799235756	1.904128458
-3	0.42476747	1.2014238	0	1.201423836	176	24	18	12	6	19.04128458	9.543248745	4.782954438	2.397155704
			2	1.512502997	192	24					12.01423836	6.021382886	3.017840231
			4	1.904128458	208	24					15.12502997	7.580471929	3.799235756
			6	2.397155704	224	24					19.04128458	9.543248745	4.782954438
			8	3.017840231	240	24	18	12	6	47.82954438	23.97155704	12.01423836	6.021382886

Single-end 2.8V
Differential 5.6V

Reserved for
speech

Connect to Driver

- **Audio driver**
 - mcu\custom\audio\XXXX_BB\audcoeff.c
 - mcu\custom\audio\XXXX_BB\nvram_default_audio.c
- **Charging Parameter**
 - mcu\custom\drv\misc_drv\XXXX_BB\chr_parameter.c
- **Flash Range Configuration**
 - mcu\custom\flash\XXXX_BB\FlashConf.c
- **GPIO**
 - mcu\custom\drv\misc_drv\XXXX_BB\gpio_drv.c
- **ADC channel assignment**
 - mcu\custom\drv\misc_drv\XXXX_BB\adc_channel.c
- **EINT channel assignment**
 - mcu\custom\drv\misc_drv\XXXX_BB\eint_def.c
- **Keypad net definition**
 - mcu\custom\drv\misc_drv\XXXX_BB\keypad_def.c
- **PWM and Battery level parameters**
 - mcu\custom\drv\misc_drv\custom_hw_default.c

Connect to Driver

- Hardware resource table
 - Flash type/Main LCM/Sub LCM
 - GPIO/EINT/ADC configuration
 - Audio connection and parameters
 - Charger parameters
 - Keypad mapping table
 - PWM & battery default level setting

Base band test items overview

- Audio (speech) FTA, Field try
- ESD test, EMC
- SIM FTA
- Melody loudness and quality test
- Charger, battery, charging algorithm
- Power on/off test
- Battery level monitor
- auto power off test.
- Low power test
- RTC alarm, accuracy and stand by time
- USB compliant test
- Component verification and quality control.
- LEDs/LCD luminance test
- Vibrator vibration and noise test
- Safety test

Base band related tools overview

- **Target**
 - Factory mode (Enter `*#66*#`) (MMI test station)
 - Engineer mode (Enter `*#3646633#`)
 - Speech UL/DL gain, side tone (normal mode, headset mode, hand free mode)
 - Echo suppressor
 - Melody gain setting
 - Key tone gain setting
 - Hardware control and monitor
 -
- **Fast download tool**
 - Code download
- **Meta tools**
 - ADC calibration (Calibration station)
 - Melody EQ fine tune
 - Speech parameter setting for FTA (PGA gain, FIR filter)
- **Hardware test tool**
 - AT command based (MMI test station)
 - Base band function test for factory
 - Hardware control for engineer

Cooperation model with customer

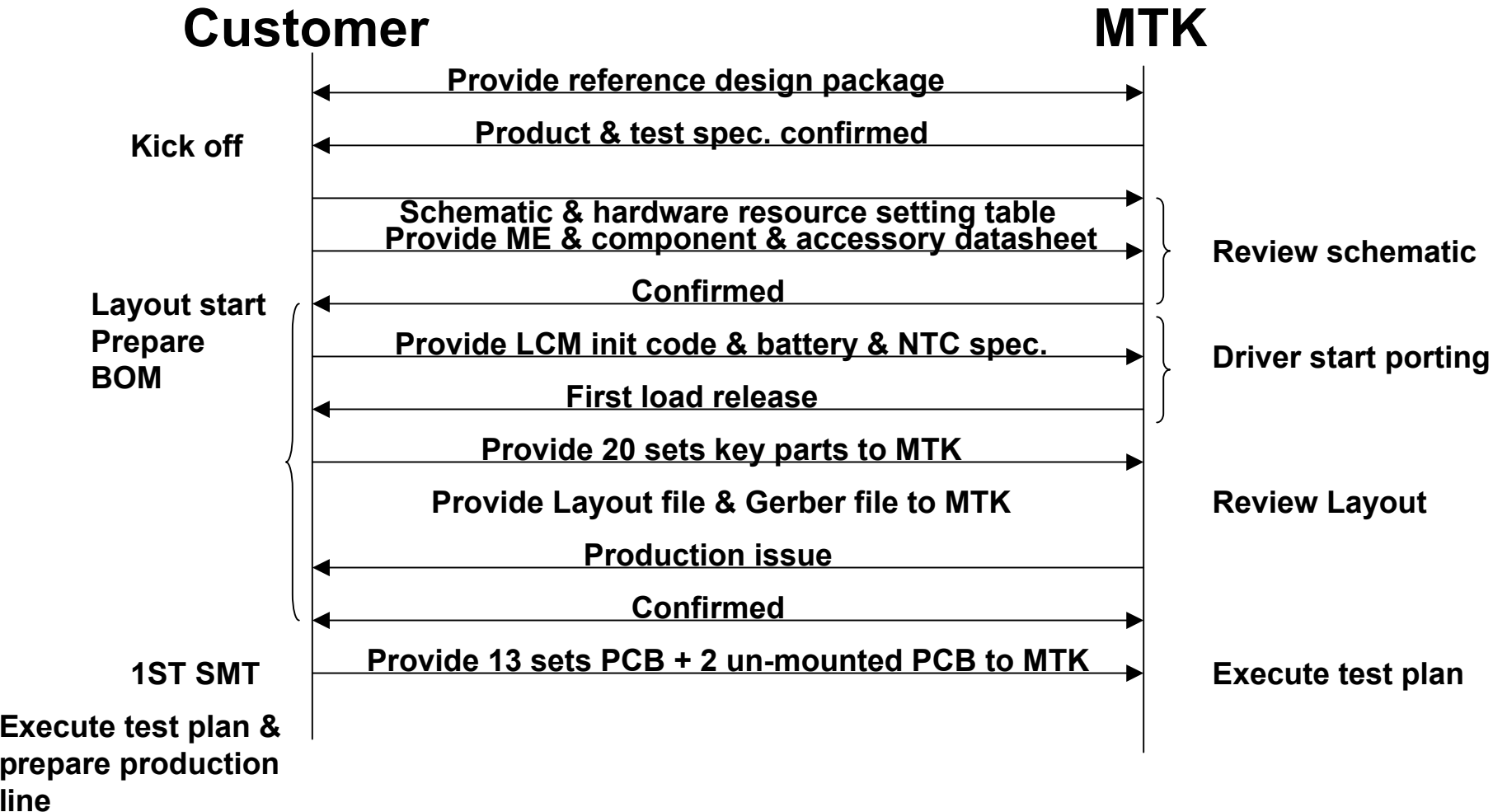

Cooperation model with customer

